DIY Apothecary Cabinet Plan



Supplies

(1) 1x12x8
(1) 1x3x8
(1) 1/2" 24" x 48" plywood
(1) 1/4" 1x6x4 (look in hobby section of Lowe's/Home Depot)
8 knobs
#8 1-1/4" screws
1-1/4" pocket screws
1-1/4" finish nails
2 sets Euro Style inset hinges
wood glue

Tools

measuring tape
square
Kreg Jig™
drill
circular saw
miter saw
table saw
hammer or nail gun

Step 1. Cut Side Panels. Cut 2 pieces of 1×12 to 28".

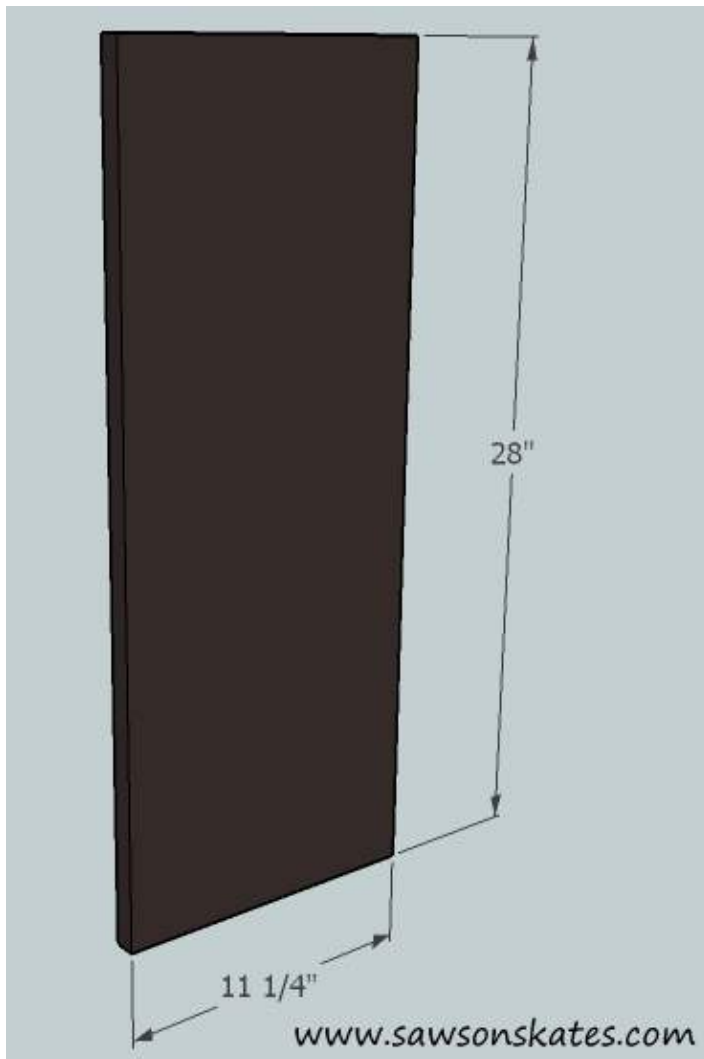

Step 2. Cut the Top and Bottom. Cut 2 pieces of 1×12 to 12-1/4" and rip to 10-3/4" wide. Drill pocket holes in each end.

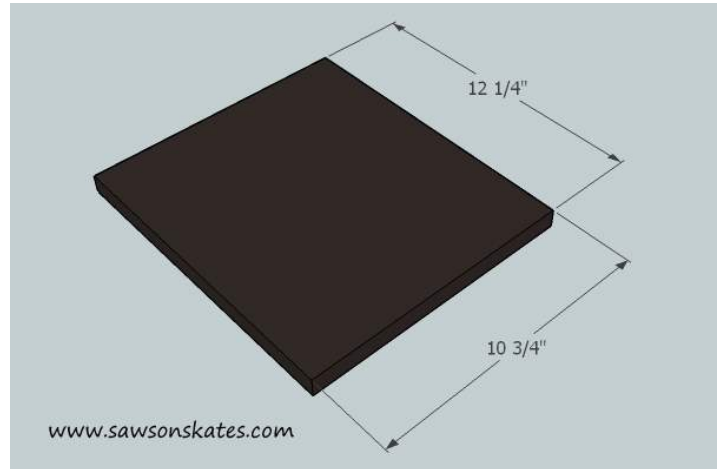

Step 3. Cut the Bottom Rail. Cut 1×2 to 12-1/4" and drill pocket holes in each end.

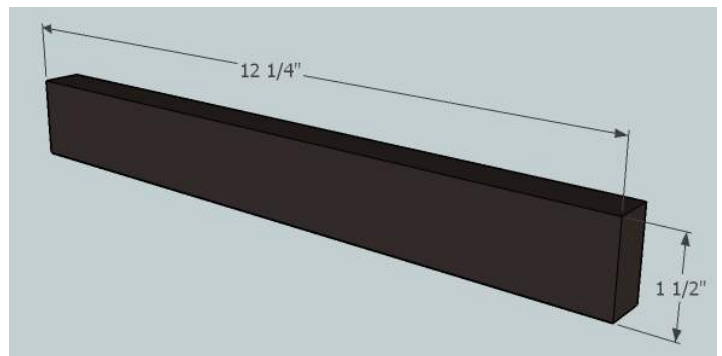

Step 4. Assemble the Case. First attach the bottom rail. The bottom rail sets in a 1/4" from the front. Apply glue to the ends of the bottom rail, clamp in position and attach using 1-1/4" pocket screws.

Next attach the bottom. Put a piece of scrap 1×2 towards the back of the case (opposite the bottom rail). The piece of scrap will support the bottom until it's attached. Apply glue to the ends of the bottom and position so the front is flush with the front of the case. Clamp, and attach using 1-1/4" pocket screws.

Finally attach the top. Apply glue to each end of the top and position so that the front edge is flush with the front of the case and the top is flush with the top of the sides.

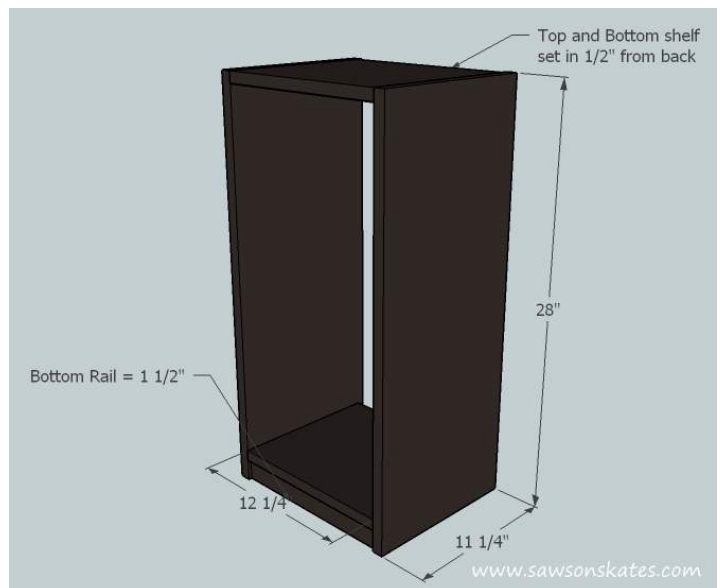

Note: Top and Bottom set in 1/2" from the back.

Step 5. Cut the back panel. Check dimensions of back opening and adjust if necessary. Cut plywood to 26-1/2" and rip to 12-1/4". Apply glue and attach using 1-1/4" finish nails.

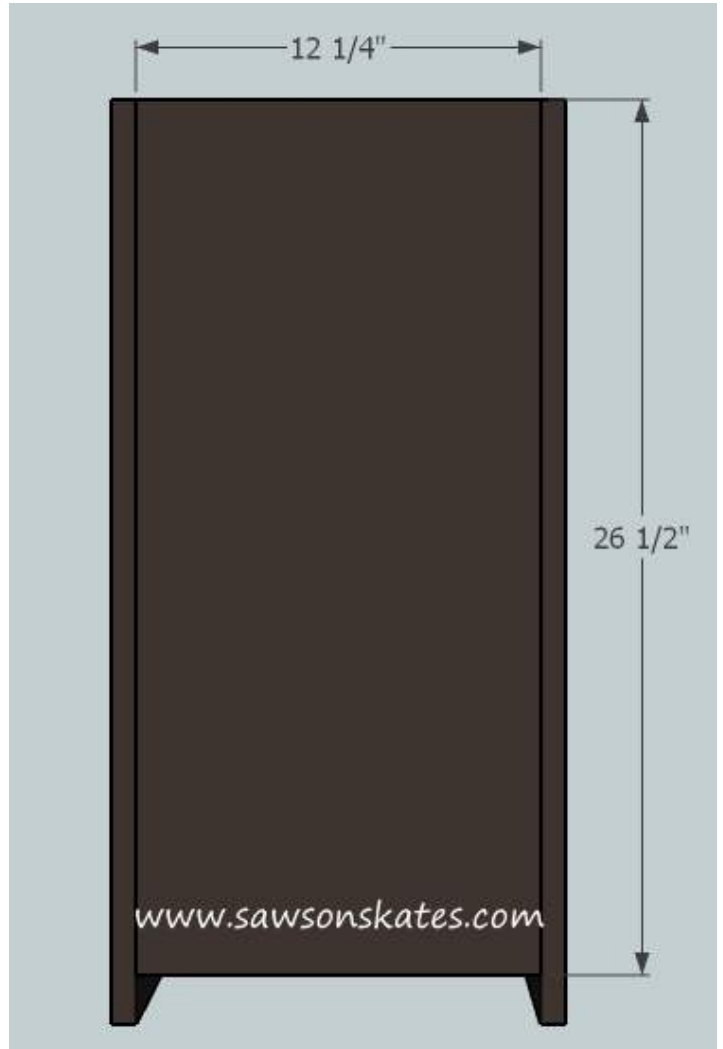

Step 6. Cut 1x12 shelf to 12-1/4" and rip to 10-1/4" wide. Cut two pieces of scrap to 12-1/8". Use the scraps to support the middle shelf and then attach shelf to sides using 1-1/4" pocket screws. Remove scraps.

Note: Shelf sets in 1/2" from the front of the cabinet and is flush against the back.

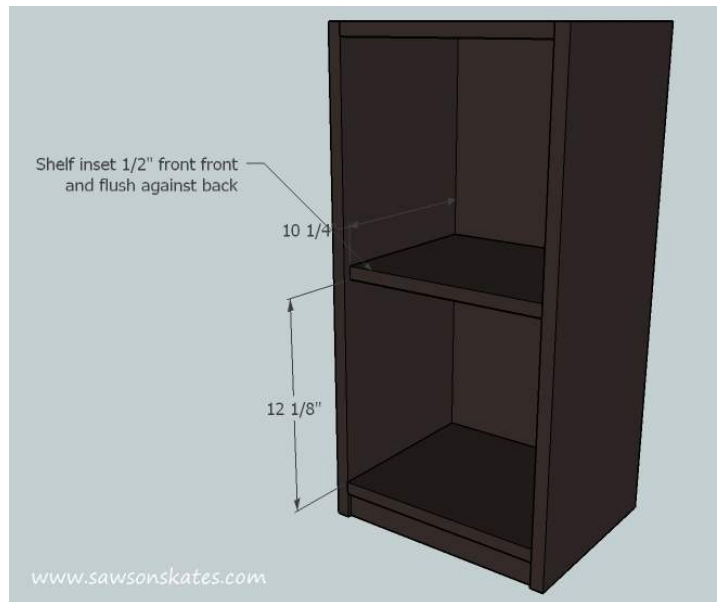

Step 7. Make the Door. Check door opening dimensions and adjust if necessary. The door should have 1/8" clearance on each side. Cut plywood to 24-3/4" and rip to 12". Cut 8 drawer fronts. The drawer fronts are held in place using the knobs. The drawer fronts set in from the edge of the door approximately 3/16" and are spaced about 3/4" apart from each other. Attach the door using 2 sets Euro Style inset hinges hinges (follow the directions that come with the hinges to install).



Step 8. Cut (5) 1x3 top pieces to 14-3/4", glue and clamp together for 24 hours. Drill four (4) elongated holes (elongating the holes allow the top to expand and contract) in the top shelf of the cabinet. From inside the cabinet, attach the top using 1 1/4" screws and washers.

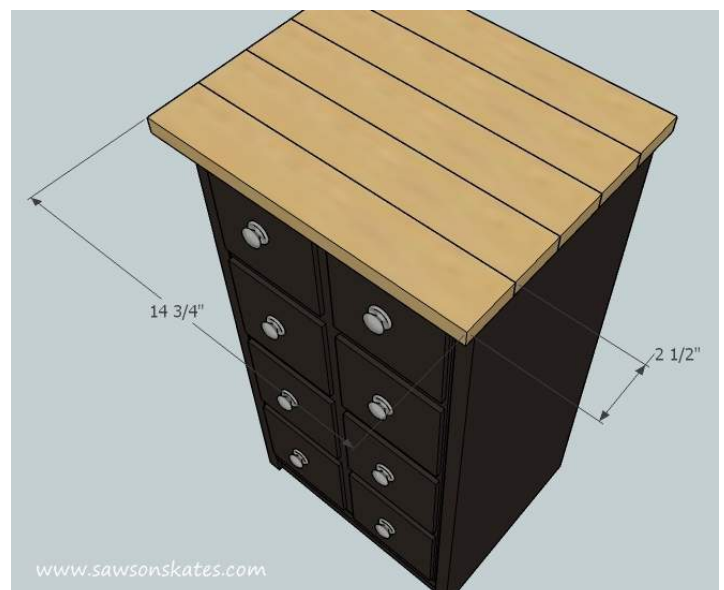

Step 9. Sand and paint or stain to finish.