

---

# Growler Carrier

---



---

## Supplies

(1) 1x6x6  
1-1/4" wood screws  
1-1/4inch pocket screws  
Corner braces  
Rust-Oleum Ultimate Wood Stain – Dark Walnut

---

## Tools

Stanley FatMax Tape Measure  
Kreg Multi-Mark  
Miter Saw  
Table Saw  
Kreg Jig  
DEWALT Drill  
1" Forstner Bit  
1-1/2" Forstner Bit

**Step 1.** Cut the Long Sides. Cut 2 pieces of 1×6 to 12-3/4".

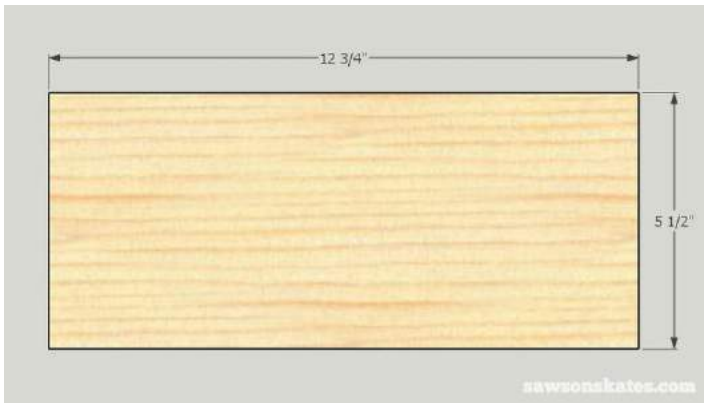

Drill countersink holes at the locations indicated below.

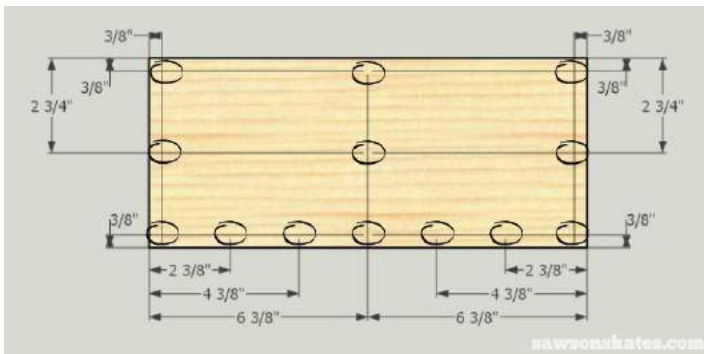

**Step 2.** Cut the Short Sides. This step differs slightly from than the photographs of my growler carrier. I updated it because the original sides didn't allow for seasonal changes and it could cause parts of the carrier to crack. Rip about a 12" piece of 1×6 to 5-3/8" and then cut 2 pieces to 5-1/2".

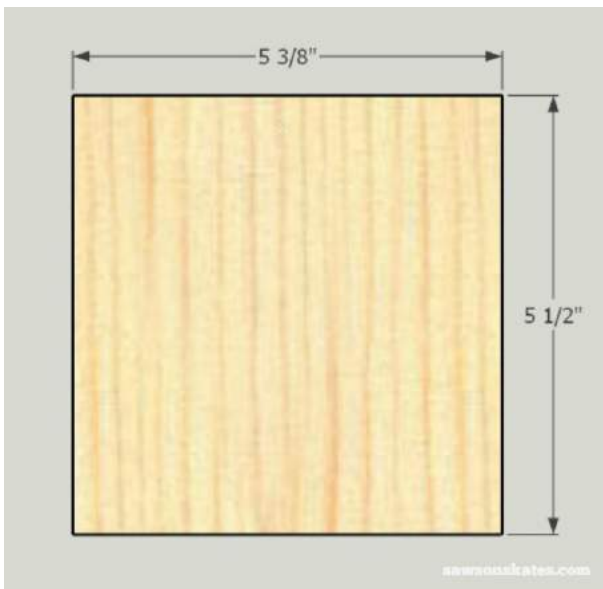

**Step 3.** Cut the Bottoms. Rip a 12" piece of 1×6 to 5-3/8", then cut 2 pieces to 5-1/4". Locate the centers of the bottom pieces by laying a straight edge from corner to corner and making a mark.

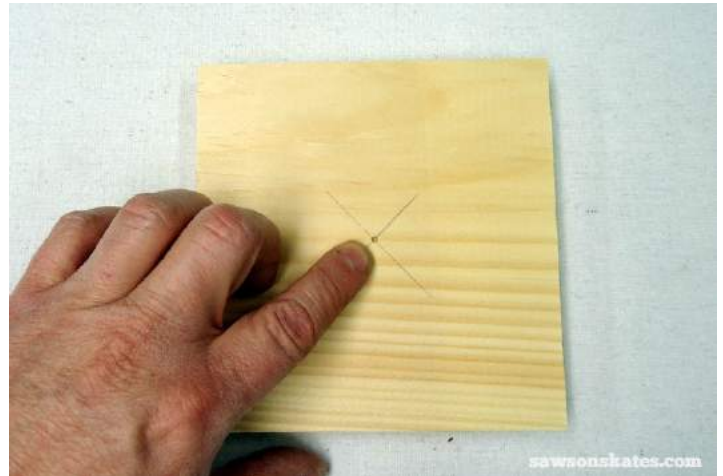

Using a 1-1/2" Forstener bit, drill a hole in each bottom.



Drill pocket holes in the bottoms in the locations shown below. Note: the left and right sides are slightly different. The left has one pocket hole that will face towards the handle and the right has two pocket holes that will face towards the handle. This configuration will prevent the screws from hitting each other.

Measure up 11-1/4" on each side and in 1-3/4".



At each location, drill a hole using a 1" Forstener bit.



**Step 4.** Cut the Handle. Cut a 1x6 to 15" and rip to 5-3/8".

Connect the top and bottom of the holes using a Kreg Multi-Mark.

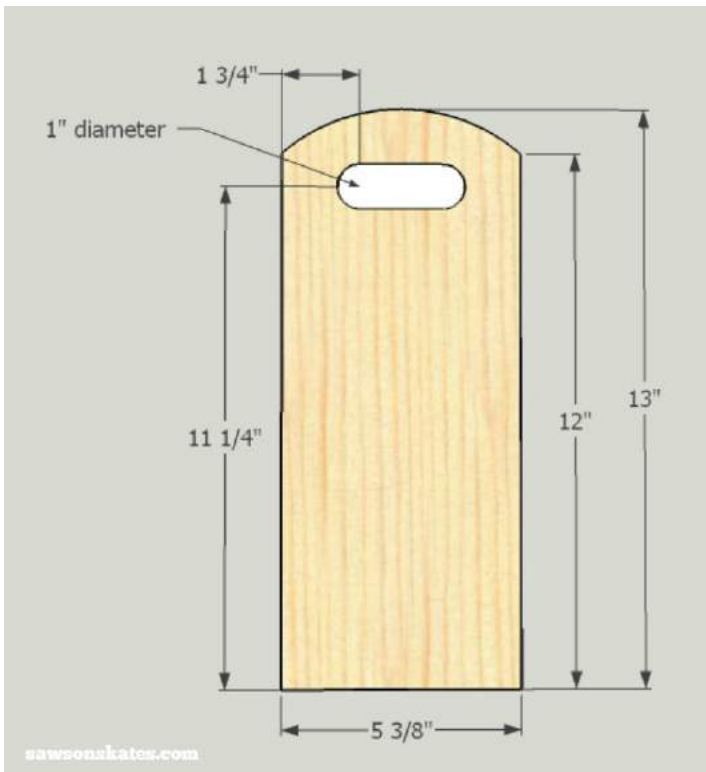

Cut the the area between the holes using a jig saw and sand smooth.



Measure up 12" on each side. I placed a sandwich plate (about 7" diameter) on each of the marks and traced the edge of the plate. Cut the curve using a jig saw.



**Step 5.** Assemble the Carrier. Layout all of the pieces and clamp. I also cut 4 pieces of scrap wood to 5-1/4". I placed the scrap between the short sides and the handle to keep the handle in the proper position.

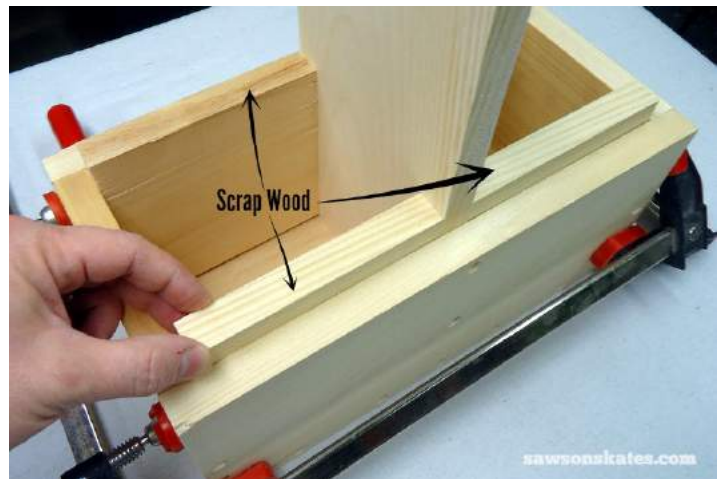

Place the bottoms so that the bottom with one pocket hole (left) faces towards the handle. Remember from Step 3 the left has one pocket hole and the right has two pocket holes. This configuration will prevent the screws from hitting each other.

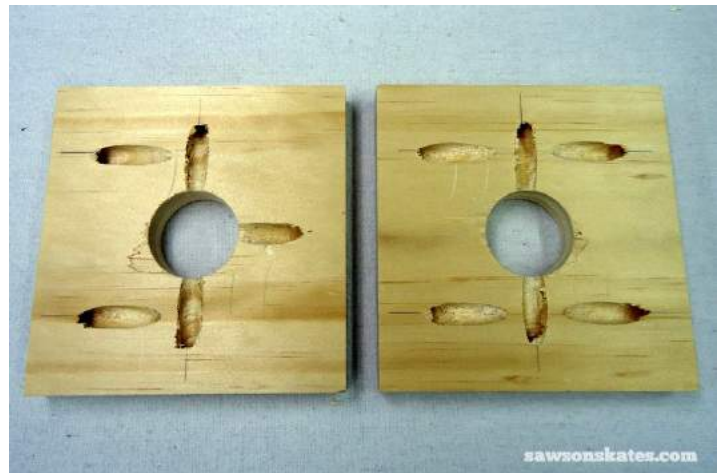

Attach the sides using 1-1/4" wood screws.



**Step 6.** Finish the Carrier. First I sanded the carrier smooth, then I applied a coat of my favorite dark walnut stain, followed by three coats of my favorite DIY finish. I wanted this piece to have a vintage, well used look, so I aged the corner braces using this aging technique.

Flip over and attach the bottoms using 1-1/4" pocket screws.



Layout the locations for the corner braces.

